

Product Support

Troubleshooting an EC Fan (Non Modbus) in a STULZ unit

In order to properly troubleshoot, a basic understanding of the circuit is necessary. The complete circuit will appear over multiple pages of the unit "as built" wiring diagram. The entire circuit consists of high voltage supply power to the fan motor, 24VAC fan control, 0-10VDC for fan speed control and 24VAC for the alarm input(s) to the controller. The following example is for a unit with 3 EC fans; as always please refer to the "as built" wiring diagram for your specific unit.

1. High Voltage Power Supply:

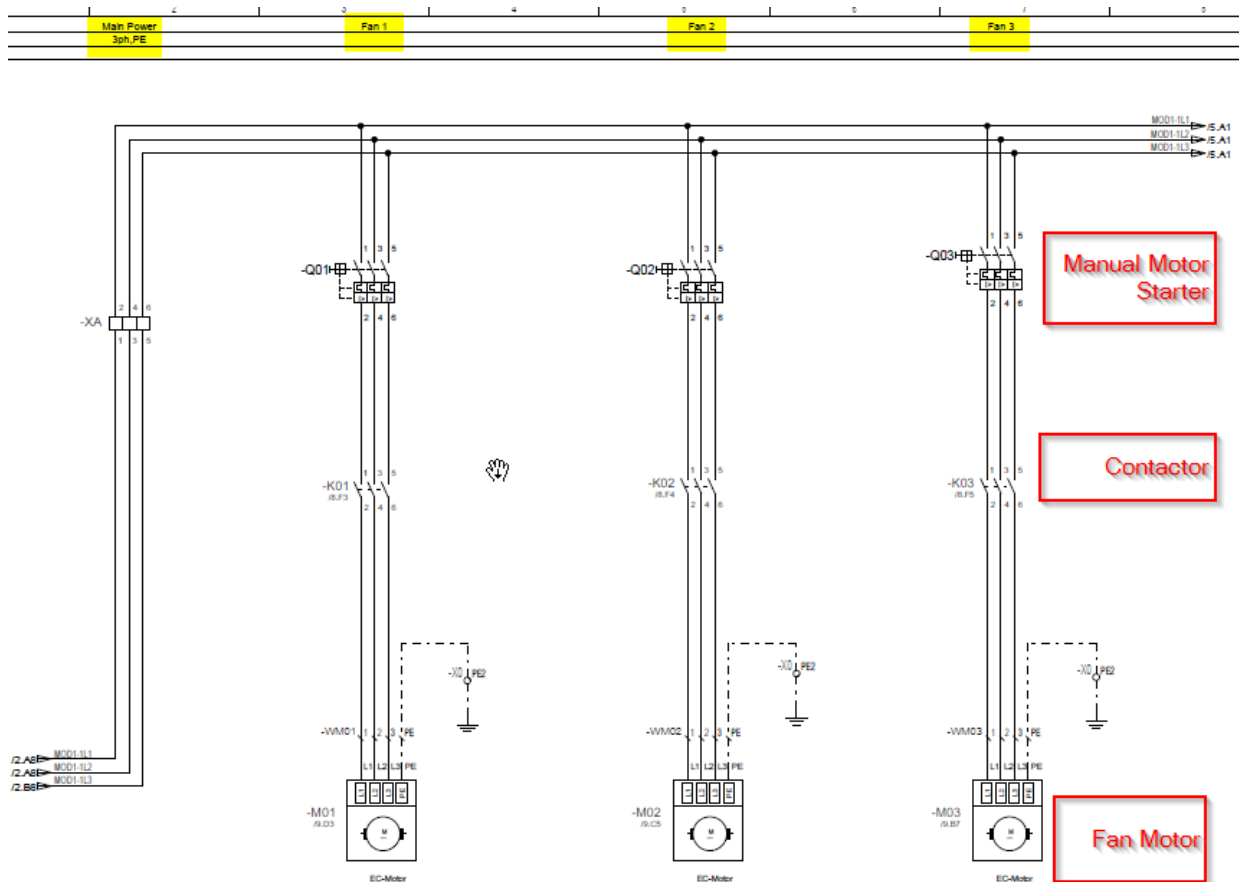

- A. Manual motor starter should be in the "On" position. If it has an adjustable trip point, it should be at the highest setting.
- B. Contactor has 24vac coil. Make sure line voltage contacts are operational and not pitted.
- C. The EC fan internally converts AC to DC for supply power. A continuity check of the motor windings is NOT an accurate way to diagnose a failed motor.

Product Support

D. All connections must be tight. The motor has internal electronic circuitry that monitors high voltage supply power. If the motor senses loss of phase, high voltage or low voltage it will not operate and will subsequently trigger a "Fan Failure #" alarm at the E2 display.

2. Fan Control 24VAC

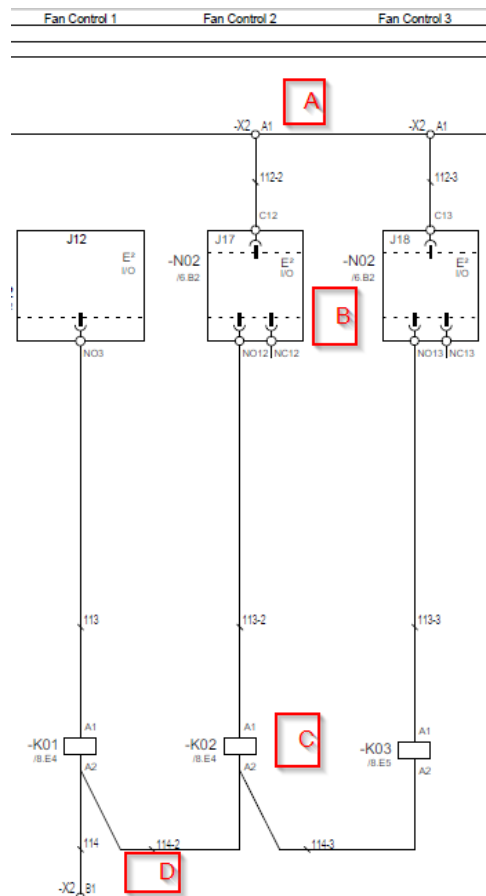

- A. (X2.A1) is a 24VAC+ bus terminal that is energized whenever the unit is powered on.
- B. The E2 controller (N02) switches 24VAC+ on a call for the fan, thus powering the fan contactor.
- C. Fan contactor coil is energized (pulled in) to power the fan.
- D. (X2.B1) is a 24VAC- bus terminal that supplies a constant neutral (common) to the contactor.

3. Fan Speed Control (proportional) 0-10VDC

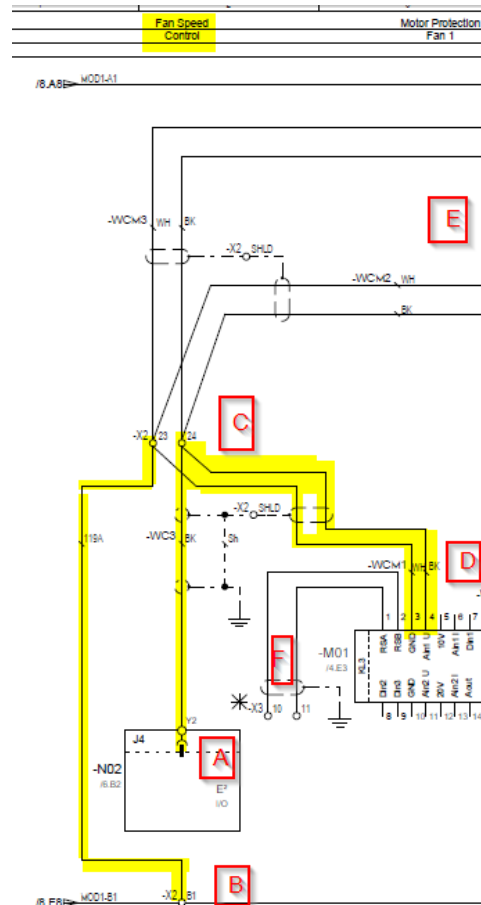

- A. The E2 controller outputs 0-10VDC+ to control fan speed thru the Y2 terminal.
- B. (X2.B1) is a 24VAC- bus terminal that also serves as the DC-(DC negative) for the fan speed signal.
- C. (X2.23 and X2.24) are terminal board numbers. These terminals serve as the junction point between the control wiring on the electrical panel and unit cabinet. Terminals provide easy access for measuring voltage while troubleshooting.
- D. The DC control signal is landed at terminals 3 and 4 of the EC motor. DC+ to (AIn1) and DC- landed at (GND). The input is polarity sensitive and the motor will not operate if +/- is reversed. A 9 volt battery can be used to simulate the DC control signal.
- E. The DC signal is wired in parallel to the other motors.
- F. The motor also has RS485 serial communication capability which can be used to access information from the motors internal electronics.



globally close to you



Product Support

4. 24VAC Alarm Input to the E2 Controller

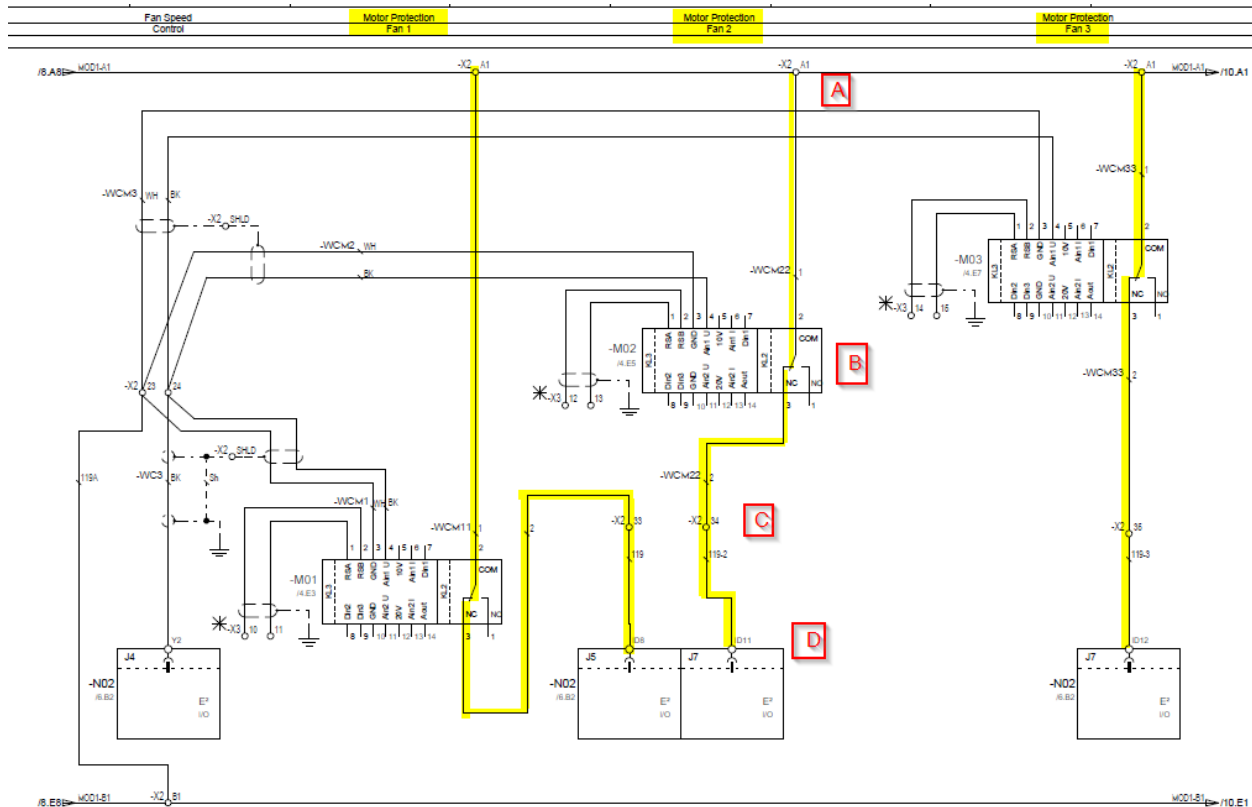

- A. (X2.A1) is a 24VAC+ bus terminal that is energized whenever the unit is powered on.
- B. Each EC fan has an internal safety relay (KL2). If the motor has no faults, the (KL2) relay contact is closed and passing 24VAC+ to the Fan Alarm Input.
- C. (X2.33,X2.34 and X2.35) are terminal board numbers. These terminals serve as the junction point between the control wiring on the electrical panel and unit cabinet. Terminals provide access for measuring voltage while troubleshooting.
- D. (ID8,ID11 and ID12) are the 24VAC+ input terminals for the Fan Alarm Circuit. The E2 will alarm on loss of voltage. For example: No voltage at ID12 will trigger a "Fan #3 Failure" alarm. When checking alarm input voltage, measure between the 24VAC+ input and 24VAC-(neutral) at input plug(as shown below)



globally close to you



Product Support

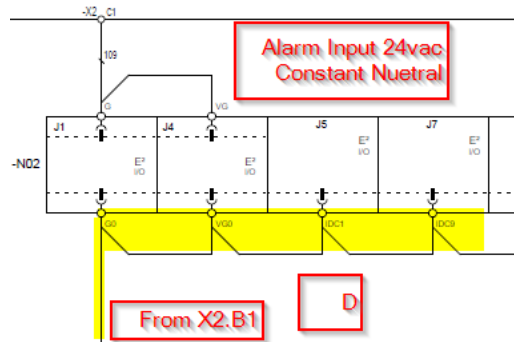

For example: To properly check the "Fan Failure" input for motor #3, the voltage would be read between J7 plug (ID12) and J1 plug (ID12).

5. Troubleshooting

- If there is no alarm but the fan isn't running, make sure the controller is turned on.
- The most common cause of "Fan Failure" alarm is loose wires, not a defective fan motor.
- Be thorough in your diagnosis. If all 3 phases of the correct high voltage power supply (usually 460/3/60) is present and DC control voltage is present ($>2.5\text{VDC}$) but the fan does not spin; then and only then can the fan motor be deemed defective.
- Use your understanding of the circuit and the troubleshooting steps below for proper diagnosis.
- The E2 controller may turn off the fan output upon losing 24VAC fan failure input. To simplify troubleshooting, install a jumper from (X2A.1) to the fan failure input (ID8, ID11, ID12). All internal fan safeties still remain effective, this simply allows the fan contactor to stay energized.



globally close to you



Product Support

